

BT21 XHD PROFILE 3

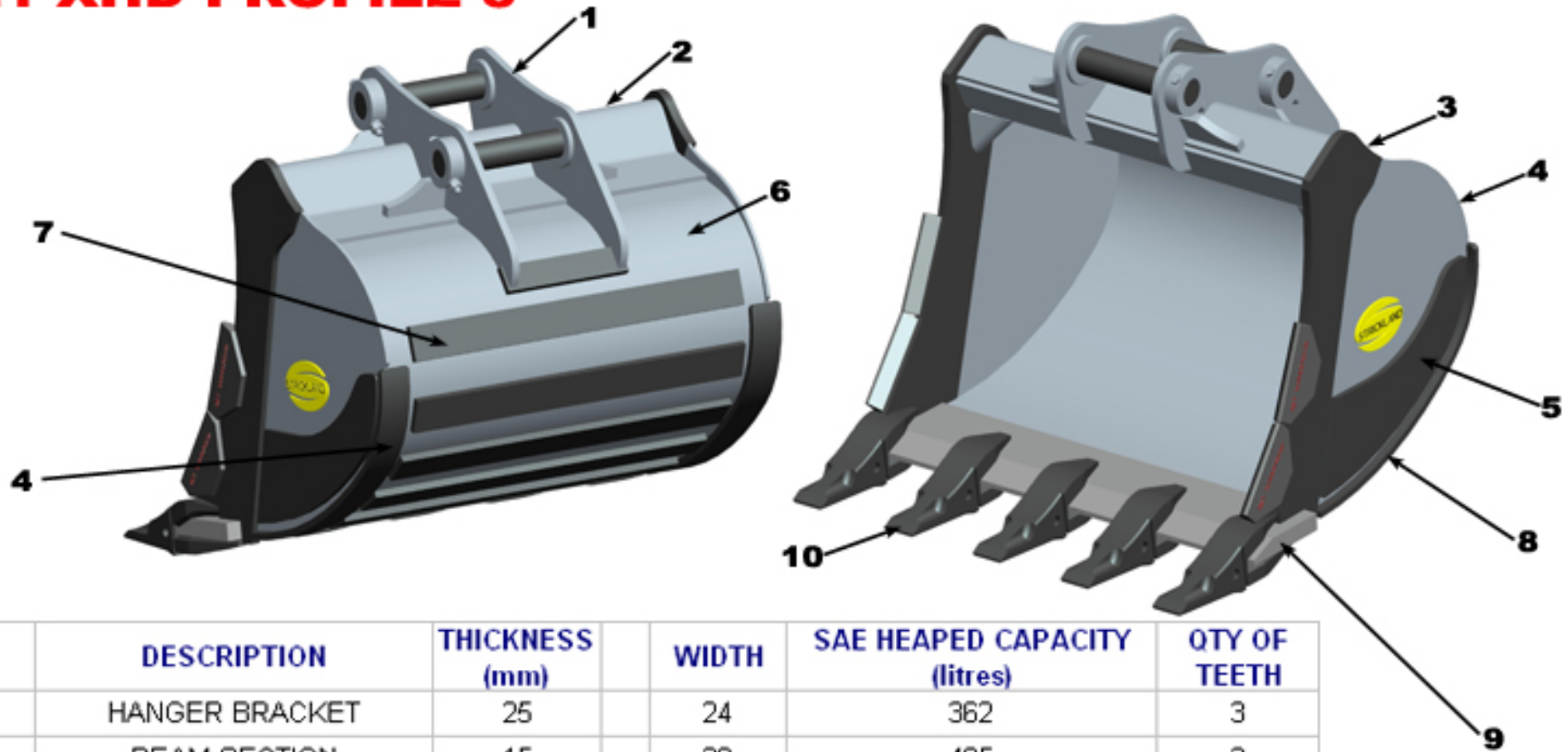

ITEM	DESCRIPTION	THICKNESS (mm)	WIDTH	SAE HEAPED CAPACITY (litres)	QTY OF TEETH
1	HANGER BRACKET	25	24	362	3
2	BEAM SECTION	15	30	495	3
3	FRONT SIDE PLATE	30	36	633	3
4	REAR SIDE PLATE	12	39	703	3
5	LOWER SIDE SKIRT	20	42	774	4
6	ROLLED BACK PLATE	12	48	916	4
7	SIDE TO SIDE WEAR STRIPS	20	54	1058	5
8	CURVED WEAR RUNNER	20	60	1200	5
9	CUTTING EDGE	50	63	1243	5
10	STANDARD TOOTH SYSTEM	QT J460	66	1342	5

